



E n e r g y i n s i d e

GRANITE SMART

B-Mount Li-ion Batteries

Models:

BB145

BB145HS

BB290

BB435

OPERATING MANUAL



For Safety reasons, this battery has been shipped in a switched-off state and is electronically disconnected.



To reactivate battery for normal operation

RECHARGE THE BATTERY TO FULL BEFORE FIRST USE

During first charge the battery gas gauge may appear inconsistent: this is a normal behaviour. The battery LEDs will be automatically recalibrated when the first charge is completed.



Read all instructions and cautionary markings in this manual and on the battery before using this product. Adhere to these instructions to prevent misuse of the products and possible injury or damage to property.

Keep these instructions. This manual contains important safety and operating instructions for the charger.

Explanation of symbols used in this manual



This symbol indicates the presence of an electrical shock hazard. It is intended to avert users not to open the product as there are no user serviceable parts inside. Any form of servicing should be done by qualified service personnel only.



This symbol is intended to alert the user to important operating, servicing and maintenance instructions within this product manual.



This symbol is intended to alert the user to the presence of uninsulated and potentially dangerous voltage within the product's enclosure that may be of sufficient strength to constitute a risk of electric shock to persons.

The contents in this operating manual are subject to change without notice.

General Safety Instructions



Danger

1. Do not disassemble or modify the battery pack. The battery pack is equipped with built-in safety/protection features. Should these features be disabled, the battery pack may leak corrosive chemicals, overheat, emit smoke, burst and/or ignite.
2. Do not connect the positive (+) and negative (-) terminals to a metal object such as a wire. Do not transport or store the battery pack together with metal objects such as jewellery, hairpins, etc. In such cases, short-circuiting or over-current flow may occur causing the battery pack to leak, overheat, emit smoke, burst and/or ignite. Metal objects such as wires, jewellery or hairpins may generate heat if they come into contact with the battery.
3. Do not discard the battery pack into fire or heat since this may cause the insulation to melt down and may also damage the gas release vents and other safety features possibly leading to chemical leakage, overheating, smoke emission, bursting and/or ignition.
4. Do not use or leave the battery pack near a heat source such as a fire or a heater (> 80°C) or in a car. If the resin separators should become damaged due to overheating, short-circuiting may occur inside the battery pack, possibly leading to chemical leakage, overheating, smoke emission, bursting and/or ignition of the battery pack.
5. Do not immerse the battery pack in fluids, water or seawater. Otherwise, the protective features inside the battery may be damaged and abnormal chemical reactions may occur, possibly leading to leakage, overheating, smoke emission, bursting and/or ignition.
6. Do not use an apparently damaged or deformed battery pack. Otherwise, electrolyte leakage, overheating, smoke emission, bursting and/or ignition of the battery pack may occur.
7. Do not recharge the battery pack near fire or in extremely hot environments. Otherwise, hot temperatures may trigger its built-in protective features, inhibiting recharging or damaging these built-in protective features, causing it to be charged with an excessive current. As a result, abnormal chemical reactions may occur internally, possibly leading to leakage, overheating, smoke emission, bursting and/or ignition.

8. To recharge the battery pack, use the battery charger specifically designed for the device and observe the recharging conditions specified by the maker of the charger. A recharging operation under non-conforming conditions may cause the battery pack to become overcharged, or charged with an excessive current. Abnormal chemical reactions may occur, possibly leading to electrolyte leakage, overheating, smoke emission, bursting and/or ignition.
9. Do not pierce the battery pack with pointed or other sharp objects. Do not strike it with a hammer, or step on it. Otherwise, the battery pack may become damaged and deformed internal short-circuiting may occur, possibly leading to chemical leakage, overheating, smoke emission, bursting and/or ignition.
10. Do not strike or throw the battery pack. An impact may cause leakage, overheating, smoke emission, bursting and/or ignition. Moreover, if the protective features inside become damaged, the resulting internally generated high current could lead to abnormal chemical reactions, electrolyte leakage, overheating, smoke emission, bursting and/or ignition.
11. Do not directly solder the battery pack. Otherwise, heat may melt down its insulation, damage its gas release vents or other safety features possibly leading to leakage, overheating, smoke emission, bursting and/or ignition.
12. Do not reverse the positive (+) and negative (-) terminals. Otherwise, during recharging, the battery pack will be reverse-charged, abnormal chemical reactions may occur, or excessively high current may flow during discharging possibly leading to chemical leakage, overheating, smoke emission, bursting and/or ignition.
13. The positive (+) and negative (-) terminals are arranged in a particular orientation. Do not force the connection if you may not easily connect the battery pack terminals to the battery pack charger or other equipment. Confirm that the terminals are correctly oriented. Reversing the terminals will result in reverse charging, possibly leading to electrolyte leakage, overheating, smoke emission, bursting and/or ignition of the battery pack.
14. Do not use the battery pack for other purposes other than those specified. Otherwise, its guaranteed performance will be lost and/or its service life will be shortened. Depending on the equipment in which the battery pack is used, excessively high current may flow through battery pack, possibly damaging it and leading to electrolyte leakage, overheating, smoke emission, bursting and/or ignition.

15. If the battery pack leaks, and the electrolyte reaches the eyes, do not rub them. Instead, rinse the eyes with clean running water and immediately seek medical attention. Failure to do this may result in eye injury.



Warning

1. If recharging operation fails to complete even when a specified recharging time has elapsed, immediately stop further recharging. Otherwise, electrolyte leakage, overheating, smoke emission, bursting and/or ignition may occur
2. Do not put the battery pack into a microwave oven or a pressurised container. Rapid heating or punctured sealing may lead to electrolyte leakage, overheating, smoke emission, bursting and/or ignition.
3. If the battery pack leaks or gives off a bad odour, remove it from any exposed flame. Otherwise, the leaking electrolyte may catch fire, and the battery pack may emit smoke, burst or ignite.
4. If the battery pack gives off an odour, generates heat, becomes discoloured or deformed, or in any way appears abnormal during use, recharging or storage, immediately remove it from the equipment or battery pack charger and stop using it. Otherwise, the problematic battery pack may develop electrolyte leakage, overheating, smoke emission, bursting and/or ignition.



Caution

1. Do not use or subject the battery pack to intense sunlight or hot temperatures such as in a car in hot weather. Otherwise, electrolyte leakage, overheating and/or smoke emission may occur. Also, its guaranteed performance will be lost and/or its service life will be shortened.
2. The battery pack incorporates built-in safety devices. Do not use it in a location where static electricity may be present. Otherwise, the safety devices may be damaged, possibly leading to electrolyte leakage, overheating, smoke emission, bursting and/or ignition
3. The guaranteed recharging temperature range is 0°C to 45°C. A recharging operation outside this temperature range may lead to electrolyte leakage and/or overheating of the battery pack, and may cause damage to it.

4. If electrolyte leaking from the battery pack contacts your skin or clothing, immediately wash it away with running water. Failure to do this may result in skin inflammation.
5. Store the battery pack in a location where children cannot reach it. Also, make sure that a child does not take out the battery pack from the battery pack charger or equipment.
6. If you find discoloration, a bad odour due to leakage, overheating and/or other irregularities when using the battery pack for the first time return it to your supplier or vendor.

Overview

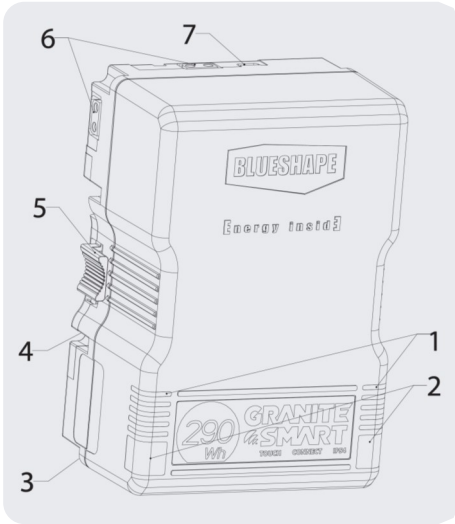

1. 5x RGB LED Array
2. Touch-sensitive Button
3. BSAFE Mounting Location
4. Contact Block
5. Release Knob
6. D-Tap Outlet x2 [16V, 80W max combined]
7. USBC-PD Outlet [5-20V, 65W max]

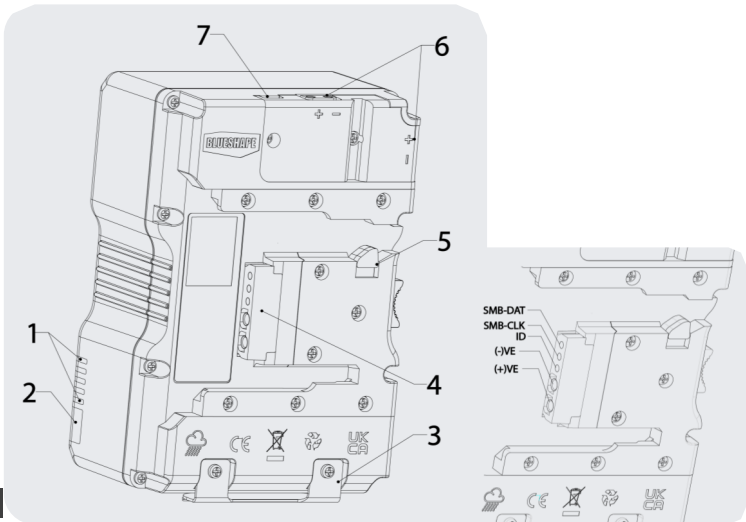

In case of the BB145HS, the battery is also equipped with a B-Mount frame that allows stacking of multiple batteries for the Hot-Swap feature.

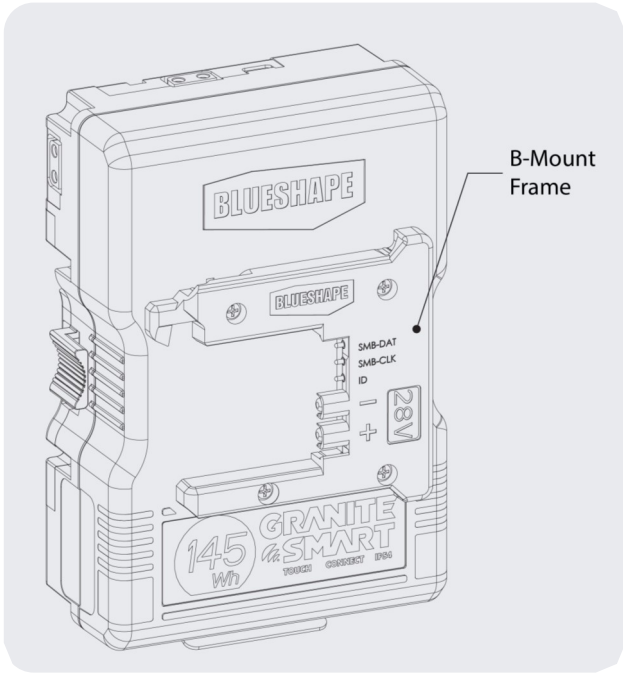

BB145HS is a stackable battery solution for the 28V B-Mount system providing a hot-swap interface for uninterrupted camera operation.

The battery hosts a B-Mount Frame on top so that another battery can be fitted. Once installed, the external battery is automatically used as the priority source but when removed the power is maintained by the hot-swap interface.

Due to its robust construction, the BB145HS also allows stacking of bigger batteries such as the BB290 and the BB435.

With a capacity within the IATA limitations, it can be transported in the carry-on luggage, max 2pcs per passenger.

Specifications

The GRANITE SMART series of B-Mount batteries consists of four models of varying capacities including a hot-swap version.

| Parameter | BB145 | BB145HS | BB290 | BB435 |
|-------------------------------------|----------------------------|----------------------------|----------------------------|----------------------------|
| Nominal Voltage | 28.8V | 28.8V | 28.8V | 28.8V |
| Operating Voltage Range | 21.0V - 33.6V | 21.0V - 33.6V | 21.0V - 33.6V | 21.0V - 33.6V |
| Nominal Capacity | 5Ah - 145Wh | 5Ah - 145Wh | 10Ah - 290Wh | 15Ah - 435Wh |
| Max Current Draw | 20A | | | |
| Max D-TAP Combined Output | 16V Regulated 80W | | | |
| USBC Output | Refer to the table below | | | |
| Operating Temperature | -20°C to 60°C | | | |
| IP Rating | IP54 | | | |
| Hot-Swap | No | Yes | No | No |
| Wireless Connectivity | Yes | | | |
| Dimensions (LxWxH) mm (LxWxH) in | 155x105x49 6.1x4.14x1.9 | 155x105x62 6.1x4.14x2.4 | 155x105x71 6.1x4.14x2.8 | 155x105x94 6.1x4.14x3.7 |
| Weight (net) | 800g (1.76lbs) | 900g (1.98lbs) | 1500g (3.3lbs) | 2200g (4.85lbs) |

USBC-C MAX OUTPUT

| | |
|-----|-------|
| 5V | 3A |
| 9V | 3A |
| 12V | 3A |
| 15V | 3A |
| 20V | 3.25A |

Introduction

BLUESHAPE professional broadcast batteries use multiple lithium-ion rechargeable battery cells. These batteries are designed for use with cameras and apparatus equipped with B-Mount working at 28V nominal.

Battery Features

- Robust, shockproof construction providing superior impact resistance.
- Rainproof **IP54 Certified** construction.
- Two 5x RGB LED array located on the edge of the front housing to guarantee maximum visibility at 270° around the battery, even if the battery is installed upside down on a stabilizer or other devices.
- The LEDs are activated by touch-sensitive switches. These switches offer several unique functions including the option to set the LEDs to remain always on, allowing for an immediate and remote glance at the battery charge status during use. The intensity of the LEDs may also be varied according to the needs of the shooting environment.
- 2x 16V D-Tap for a combined max output-only of 80W.
- 1x USB-C-PD 5V~20V up to 65W useful to power an array of devices (PD 3.0, PPS 63W and QC 4.0).
- The USB-C output is also equipped for the useful and unique personal **SMARTMon** function that provides each user with the ability to interface with their battery via a simple USB-C data cable to monitor and control its functions in direct connection with our customer service.
- The new GRANITE SMART wireless connectivity boosts the usage in the field: compatible with most smartphone and tablets, connects immediately out of the box and helps to control all the batteries in real time during use without lengthy pairing operations.
- The new B-mount range is ready for use with the optional **BSAFE**, a market first metal bracket that secures the battery to the safety cable system when used on overhead equipment.
- The battery will shut down if the maximum specification discharge current for the model in use is exceeded. It will reset approximately 30 seconds after the excessive load has been removed. The battery will also shut down when fully discharged but will reactivate upon charging. Pre-Charge is enabled on all batteries to limit the charging current and gently charge low voltage cells. Further protections are enabled to avoid battery

operations outside the safety parameters of the Li-Ion cells. In extreme cases, when the failure are not recoverable the battery will be permanently disabled, and only further inspections may re-enable the battery.

- The battery has implemented power saving modes that act differently if the battery is inactive and installed on a device (either a Camera, a Charger, a Lights and so on) or is left inactive on the shelf. For maximum performance and power saving, we suggest not to leave the battery installed for a prolonged period of time if inactive.

Further Precautions

- BLUESHAPE B-Mount batteries are single voltage batteries operating at 28V nominal.
- Please consult your vendor before use, to ensure compatibility with your equipment. Although the battery has been designed for use with most standard B-Mount equipment operating at 28V nominal, there may be instances when the battery may not be compatible.
- Please consult your vendor before use, to ensure compatibility with your equipment. Although the battery has been designed for use with most standard B-Mount equipment, there may be instances when the battery may not be compatible.
- Never attempt to open or dismantle the battery.
- Opening the battery during warranty will automatically invalidate the guarantee.
- Do not short circuit the battery even though it is short circuit protected.
- Do not use the battery in extreme temperature environments.
- Keep the battery away from fire to avoid explosion.

Charging

The battery can be charged using BLUESHAPE chargers. Consult your vendor if you intend to charge the battery using third-party chargers, ensuring that they are designed for 28V nominal batteries.

Since the battery is normally shipped in ultra-low power consumption mode, **it needs to be charged before first use.**

The battery may become hot during charging. This is normal. Consult your vendor if during charging, the battery becomes excessively hot or stops charging. Charging is only allowed at temperatures between 0°C and 45°C. While charging, the LED indicator lights up automatically to show the battery capacity as it increases.

Performance

- The battery will give full capacity performance only if it has been fully charged before use.
- The battery will self-discharge to some extent over time due to internal electronic consumption. Recharging will restore this lost capacity.
- It is recommended to charge the battery after each use, and before an expected prolonged shelf period.
- Performance degradation may be observed in very cold or very hot environments.
- Performance decreases as the battery ages, if it has a high cycle count or if it is not stored at the recommended temperature. When the performance noticeably decreases, the battery should be renewed.

LED Operations

- By touching any of the sensitive area, the LED array are enabled and they will show the battery relative state of charge. Once activated the LEDs will stay on for 5 seconds.
- The state of charge is shown using 5 LEDs, with each LED representing 20% of the charge. The fully lit top LED indicates a charge between 11% and 20% for the respective segment, and a blinking LED indicates a charge between 1% and 10%. The LEDs will remain always ON during charge to provide an immediate visual indication of the state of charge.
- The LEDs can be set to stay ON by touch-and-hold any of the areas for 10 seconds. When set to stay ON, the brightness can be changed by touch-and-hold one side while tap the other: at every touch it will cycle between high, normal and low to adapt to the shooting environment. To turn off the LEDs, touch-and-hold again for 10 seconds.

Auxiliary Power

D-TAP

- The battery is equipped with 2x D-Tap power outlets that release 16V regulated. With a maximum combined output of 5A (80W). If that happens the voltage will suddenly drop and switch off. No input is allowed from these two ports.
- The DTap ports are always switched on when the battery is installed on any B-Mount enabled device, and will remain enabled until the battery is active.

- When the battery is not installed on a B-Mount, the D-Tap ports are switched on by touching any LED tap area, and will remain enabled until the battery remains active delivering power plus 10minutes.

USBC-PD

- The USBC outlet is capable to deliver up to 65W according to the following standard: PD 3.0, PPS and QC 4.0. This means that the battery is capable to regulate the output voltage of this port based on the request of the connected device needing power in a range between 5V and 20V, typically smartphones, tablet, portable computers and in general any device compatible with the above standards. Additionally this port permit the connection of the battery with the USB data port of a computer for use of our personal **SMARTMon** app for battery diagnostic and utility.
- The USB-C port is always switched on when the battery is installed on any B-Mount enabled device, and will remain enabled until the battery is active.
- When the battery is not installed on a B-Mount, the USB-C port is switched on by touching any LED tap area, and will remain enabled until the battery remains active delivering power plus 10minutes. Alternatively, the simple connection to the **SMARTMon** app wakes up the battery for communicating with the PC.

Storage

The battery should be stored in a dry place at normal temperatures, ideally below 25°C and not above 60°C (recommended 0°C to 20°C) The battery is shipped in ultra-low power consumption mode and in this state can withstand long period of storage. However, after the battery has been reactivated with the first charge, more attention and care are needed:

- It is recommended to charge the battery after each use.
- If the battery is not going to be used for a prolonged period of time, it is advisable to recharge the battery so as not to store it in a very low state of charge. Remember that there will always be some internal power consumption.
- It is advisable to check the state of charge every 6 months and if possible to exercise the battery regularly.
- Do not leave B-mount batteries installed on equipment such as chargers cameras or other devices if inactive for a long period of time because this will create an unnecessary power leakage.

- A B-Mount battery not in use for a long time will automatically enter in an ultra-low power consumption mode, and will result completely deactivated, after about 45 days of inactivity. It will resume to normal operation by applying a charge.
- With the personal **SMARTMon** free tool, it is possible for the user to force the battery in the ultra-low power mode, that is convenient to prepare the battery for a long period of storage or for shipment.

Battery Wireless-Connectivity

All GRANITE SMART batteries have an embedded BLE module that is the core of the GRANITE SMART architecture. This module is normally on by default.

How to switch it on

The BLE module is on by default and it is only off when the battery is inactive. Touch one of the two touch sensors to turn the battery back on.

How to switch it off

The battery will deactivate automatically after 10 minutes of inactivity if not installed on any device, or after 30 minutes of inactivity if installed on a Camera, a Charger or any other B-Mount enabled device.

Operation

The Battery can be monitored via Bluetooth Low Energy (BLE) through any BLE-enabled smartphone or tablet using our **GRANITE SMART** app.

The BLE module transmits essential data periodically, facilitating convenient at-a-glance monitoring of the battery.

Establishing a connection to the Battery yields more comprehensive information, including:

- Voltage
- Current
- State of Charge
- Capacity
- Residual Runtime to Empty
- Cycle Life

Simultaneously, the battery can receive user-generated data, enabling actions such as modifying the visible name of the battery and issuing commands for the battery to make itself visually identifiable.

15 Upon receipt of the "findme" command, the battery will signal its presence by blinking the topmost LED in red and green, serving as an indicator that it is the currently monitored battery.

BLUESHAPE GRANITE SMART App

Available soon

Battery Disposal



This GRANITE SMART battery is not permitted to be disposed of with household waste. Different countries have different regulations on recycling. Strictly follow your local regulations regarding the disposal and recycling of batteries and consult the responsible authority in your country for further information.

Air Transport (IATA regulations)



All BLUESHAPE batteries meet the standard of the UN Manual of Tests and Criteria, and therefore can be transported by air. Li-Ion batteries can be transported by air only in carry-on baggage, either stand-alone (UN3480) or packed with equipment (UN3481). For check-in of Li-Ion batteries to be allowed, it is advisable to pack them in their original

boxes using the contact protectors provided for additional safety.

Li-Ion batteries less than 100Wh can only be transported by air in carryon baggage and in reasonable (though unlimited) quantities, either standalone (UN3480) or packed with equipment (UN3481).

For Li-Ion batteries that have capacities between 100Wh, and 160Wh, users can carry 2 units only and in their hand luggage.

The BB145 and BB145HS model falls under this category.

Models larger than 160Wh have to be presented and can only be carried as cargo in accordance with IATA dangerous goods requirements. This applies to batteries on board equipment and also spare batteries. The battery terminals should be protected from short circuit preferably by enclosing the battery in its original packing box and plastic bag and using the contact protectors provided.

The BB290 and BB435 fall under this category.

It is suggested to check with your airline in case the latter applies different policies or if there exists, different legislation in your country.

IATA approved Battery flight cases

Soon available dedicated Flight cases for the BMount line-up

Warranty

BLUESHAPE batteries are warranted to be free from defects in materials, workmanship and functionality for a period of 18 months commencing from the date of purchase. This warranty shall not apply to any products or parts there-of, that have been subjected to misuse, negligence, accidental or abnormal conditions of operation.

The buyer should always contact the place of purchase for any return of defective product. It is important that the buyer provides us with as much information as possible about the failure being claimed. In the event of product failure for which warranty applies, we will repair or replace the product free of charge. In these cases, all expenses including transport charges will be borne by us. In the case where the failure has been caused by one of the causes explained above, repairs shall be billed at a nominal cost. Prior to the carrying out of any repairs, we will inform the customer of the estimated costs of these repairs.

These warranty conditions are the only ones applicable to our products and overrule any other expressed or implied warranties. We shall not be held liable for any damages resulting from warranty statements other than those contained in this declaration.

This warranty is not transferable and is only applicable to the original buyer. In all warranty claims, the buyer must reproduce the original purchase invoice.



BLUESHAPE®

is a registered trademark of:

NEW CELL TOP Srl

Via Liguria 4-6,

42124 Reggio Emilia, ITALY

TEL.: +39 0522 518556

WEB: www.blueshape.net

EMAIL: info@blueshape.net