



Li-Ion Portable Power Generator

**PG700E/U - 700W 1150Wh Ruggedised Inverter Power
Station**

Operating Manual

Revision 1.01

www.blueshape.net

Printed in Malta 2022



Read all instructions and cautionary markings in this manual and on the power-generator before using this product. Adhere to these instructions to prevent misuse of the products and possible injury or damage to property.

Keep these instructions. This manual contains important safety and operating instructions for the PG700 power-generator (the device).

Explanation of symbols used in this manual



This symbol indicates the presence of an electrical shock hazard. It is intended to alert users not to open the product as there are no user-serviceable parts inside. Any form of servicing should be done by qualified service personnel only.



This symbol is intended to alert the user to important operating, servicing and maintenance instructions within this product manual.



This symbol is intended to alert the user to the presence of uninsulated and potentially dangerous voltage within the product's enclosure that may be of sufficient strength to constitute a risk of electric shock to persons.

The contents of this operating manual are subject to change without notice.

General Safety Instructions

Warning

Earth the power-generator before using it as a power source to any other device or equipment. To earth the power-generator, remove one any of the four front-facing panel cap nuts and attach an earthing lead with an M6 ring terminal. The other end of the earthing lead must be terminated with:

- an earth rod inserted into the ground or
- a crocodile clip attached to a conductive earthed structure.

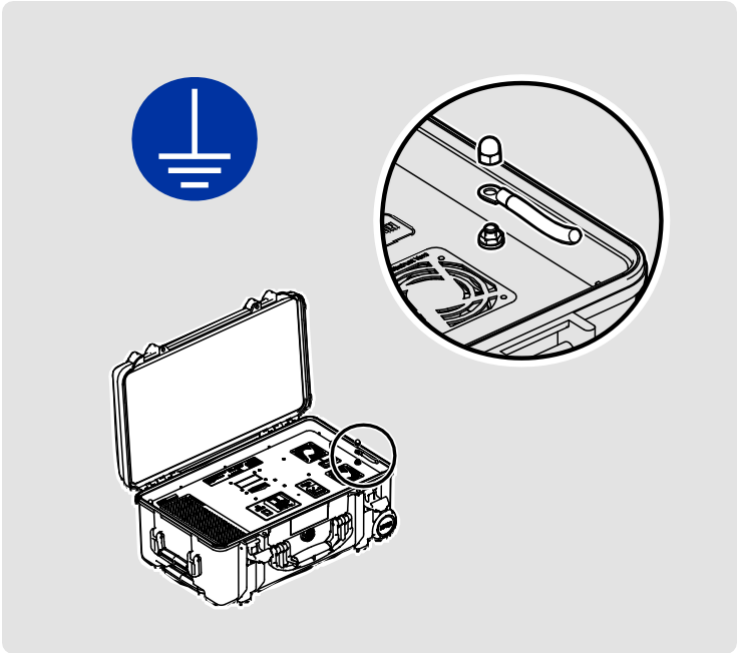

The equipment is being supplied with a compatible AC mains power cord. In the case when the UK plug is fitted, this plug is equipped with a 13A replaceable fuse. Damage to the power cord can lead to an electric shock.



This device outputs voltages that can cause injury or death.

Danger

- Do not disassemble or modify the device.
- Do not discard the device into fire or heat.
- Do not leave the device near a heat-source such as a fire or heater.
- Do not operate the device next to combustible gasses.
- Do not submerge the device in water or other liquid, whether in operation or otherwise.
- Do not pierce the device with pointed or sharp objects.
- Do not strike the device with blunt objects.
- Do not subject the device to excessive mechanical shock.
- Do not use the device if it is apparently damaged or deformed.
- Only connect mains plugs compatible with your device.

Warning

- If recharging operation fails to completed even when a specified recharging time has elapsed, immediately stop further recharging.
- Do not subject device to excessive micro-wave radiation.
- Do not subject device to excessive ambient pressures.
- Do not insert any objects into the device such as through its ventilation.
- If the device gives off an odour, generate excessive heat, becomes discoloured or deformed, or in anyway appears abnormal during use, recharging or storage; disconnect it and stop usage immediately.
- The operating temperature range is 0°C to 40°C. Operation outside this temperature range may affect functionality and may lead to damage to the device.



Caution

- To reduce the risk of injury, close supervision is necessary when this device is in use near children.
- Keep out of reach of children.
- Only use attachments recommended or sold by manufacturer.
- Do not handle the device outlets or inlets with damp hands.
- Always place and operate the device on level ground.
- Only carry the device from the appropriate carrying handles.
- Do not operate the device with damaged power-cords. Replace any damaged cords immediately.
- Do not obstruct ventilation - always operate the device with the lid wide open.

PG700 Package Contents

The PG700 package contains the following:

- PG700 portable power generator
- AC power cord [according to region]
Device-End Connector: IEC 60320 C13
EU Plug: IEC 884/CEE7-VII3
UK Plug: BS1363A w/13A FUSE
US Plug: NEMA 5-15-P
- Operating Manual

Overview

The BLUESHAPE portable power generator is a Lithium-Ion (Li-Ion) based alternating current (AC) inverter. The embedded Li-Ion battery bank includes protection circuitry and electronics to ensure cell longevity and product safety. This power-generator has an embedded pure-sine wave inverter to generate clean and reliable alternating current for substitute power when a mains supply is inaccessible or interrupted. This is an all-in-one product, which also features built-in charging capability.

The PG700 is built in a rugged portable hard case. When the lid is closed for storage and handling; it can withstand shocks as well as dust and water ingress.

Operational Modes

The device can operate in the three modes:

- Charge Mode
- Inverter Mode
- Online UPS Mode

PG700 Features

- Pure sine-wave Inverter
- Portable form factor with wheeled case
- Ruggedised construction
- IP67 enclosure for storage and transport
- Display with inverter and battery status
- Low-noise operation
- Integrated quick-charger
- Silent-charging
- 200W uninterruptible power supply

Graphic Description

Storage and Handling

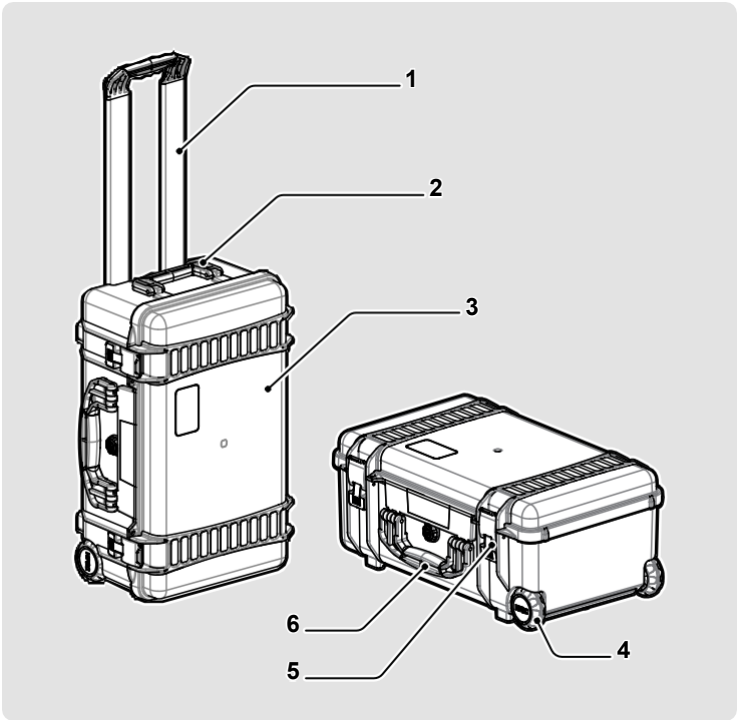

The PG700 is constructed in a rugged hard-case and consists of the following:

1. Telescopic Handle
2. Upright Carry Handle
3. Enclosure Lid
4. Roller Wheels
5. Lid Latches
6. Mid Carry Handle

Operation

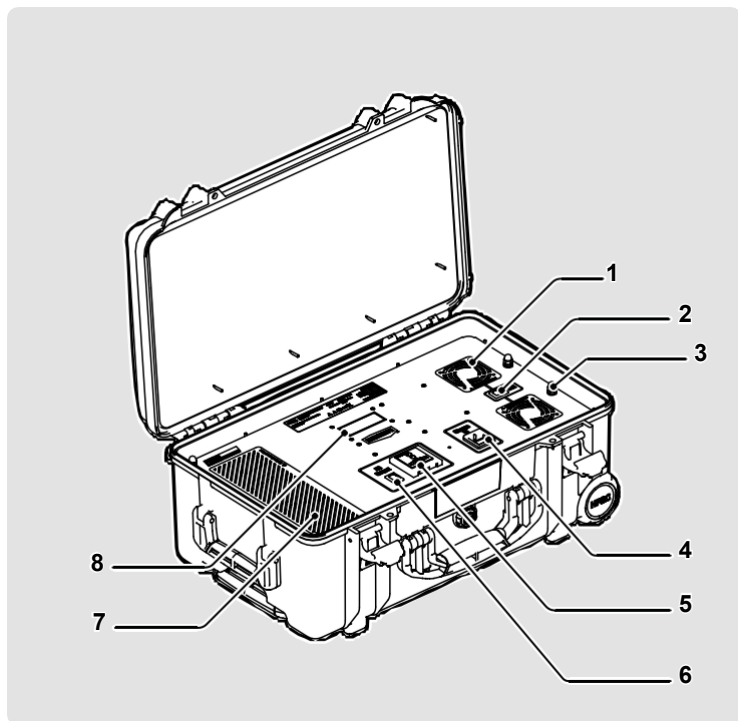

The PG700 front facing panel consists of the following:

1. Exhaust Fans
2. Silent Charging Switch
3. Front Panel Cap Nuts
4. Charge AC Input Socket
5. Mains Outlet
6. Mains Output Switch
7. Intake Ventilation
8. Display

Operating Instructions

This section details the operational procedure for this power-generator. The last sub-section details the different statuses, warnings and errors shown on the display.

Charging the Device

To charge the device:

1. Switch off mains output switch
2. Connect the provided IEC 60320 C13 lead into the socket labelled 'charge in'.

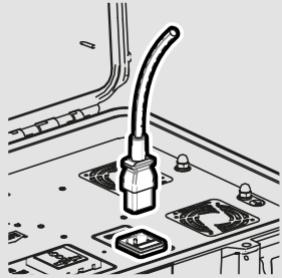

Note: Charging will still work with the mains output active or idle. Unless the inverter functionality is required, switch off mains output to ensure pack longevity.

The display will show a charge progress bar and will indicate the estimated time until fully charged.

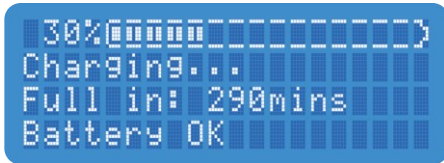

To activate silent charging press the fan switch to the off position to disable the fan during charging.



Use silent charging only when necessary, cooling the internal electronics during charging will ensure the longevity of the device.

Operating the Device in Inverter Mode

To use the mains output:

1. Connect a compatible mains cable to socket labelled 'AC Output'.
2. Press the switch to the on position.

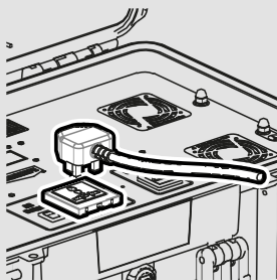

Unless the device is equipped with a universal mains socket, be sure to match the mains cable with the socket fitted in the device.



Be sure that the electrical load does not exceed the maximum power rating of the power-generator.

The display will show a charge remaining bar and will indicate the estimated time till complete charge-depletion. In the second display row, an indication of the operational power relative to the maximum power rating is shown.

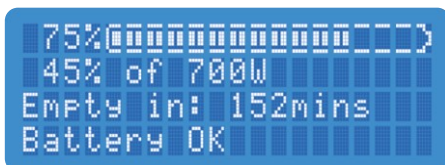

The last line of the display shows warning or error codes such as warning when the charge has reached a low-level. Refer to the error code section for further details.

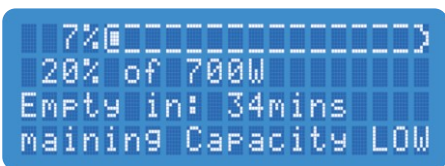

Notes on Inverter Mode Behaviour

This device is equipped with multiple safety features to safe-guard use and device longevity.

- If the electrical load attached to the device is in excess of the power generator's maximum power rating, an audible alarm will sound to alert the user. Once the load significantly exceeds the power-generator's load rating the mains output will cut-off. The power-generator will attempt to restart until the load is reduced to an acceptable level.
- If the packs report an over-temperature error, the power-generator will shut down until the pack temperature falls to an acceptable level.
- When the device charge is empty, the inverter function will be disabled until the device is charged to at least 5% capacity.

Operating the Device in Online UPS Mode - 200W

This power-generator can also function as an Online UPS, only if the electrical load is less than 200W.

Loads larger than 200W will eventually deplete the internal batteries nonetheless.

To use the device in UPS mode:

1. Connect the provided IEC 60320 C13 lead into the socket labelled 'charge in'.
2. Connect a compatible mains cable to socket labelled 'AC Output'.
3. Press the switch to the on position.



Use this mode as necessary, unless a mains output is required. Switch off the mains output when charging the device to ensure its longevity.

The display will show a charge remaining bar and will indicate the estimated time until fully charged.

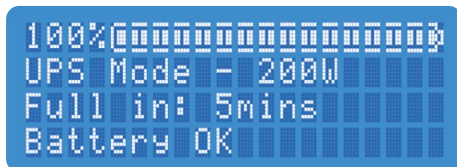

If the AC input via the 'charge in' socket is interrupted, the AC output will be uninterrupted and maintained until the charge is depleted.

Status, Warnings and Errors

This section details the different warnings and errors which may be shown on the last line of the display.

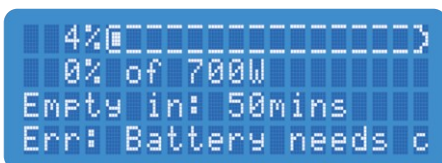

| Type | Display | Description |
|---------|------------------------------|---|
| Status | Battery OK | Status is fine and device ready for use. |
| Status | Battery Full | The battery has fully charged. |
| Warning | Remaining Capacity Low | Battery capacity has fallen below 10%. |
| Warning | Remaining Time Low | Battery remaining time is less than 10 minutes. |
| Warning | Waiting for battery to cool! | Charging is inhibited until the battery temperature is below 35°C. |
| Warning | Battery thermal limit! | The battery is approaching the temperature limit for discharge. The Inverter may cut off at any time. |
| Error | Inverter Error | Inverter has flagged an error. |
| Error | Bat Overcharged | An internal battery pack has been overcharged. |
| Error | Over-temperature | An internal battery pack has exceeded the thermal operation limit. |
| Error | Battery needs charge (5%)! | Battery has been fully discharged and must be charged before the inverter is enabled. |

Technical Specifications

The PG700 comes in different model variants. To clarify your model number, check the front panel markings.

PG700E

| | | Battery Capacity | |
|----------------|------|------------------|--------|
| | | 1150Wh | 1500Wh |
| Voltage Output | 110V | | |
| | 220V | | |
| | 230V | ● | |
| Frequency | | 50Hz | 60Hz |
| | | ● | |

PG700U

| | | Battery Capacity | |
|----------------|------|------------------|--------|
| | | 1150Wh | 1500Wh |
| Voltage Output | 110V | ● | |
| | 220V | | |
| | 230V | | |
| Frequency | | 50Hz | 60Hz |
| | | | ● |

| Parameter | Specification |
|---|--|
| Output Voltage | 240/110 V AC 50/60 Hz (Model Dependant) |
| Max. Continuous AC Power Output | 700 W |
| Max. Instantaneous AC Power Output | 800 W |
| Internal Battery Capacity | 1150/1500 Wh (Model Dependant) |
| Approx. Charging Time | 7 Hrs |
| Dimensions / mm [in] | 549 x 346 x 236 [21.61 x 13.62 x 9.29] |
| Weight | 18 Kg 39.68 lbs |
| Operating Temperature | 0 - 40 °C 32 - 104 °F |
| Charging Temperature | 0 - 40 °C 32 - 104°F |
| Storage Temperature | -20 - 65 °C -4-219 °F |

Storage and Handling

- When storing or handling the device always use the appropriate carry handles.
- Be sure to secure the lid by closing the latches this will ensure the hermetic performance of the enclosure's seal.
- Clean only with a dry cloth.
- Do not rest heavy loads on this device.
- Do not sit on the device.



Be sure that mains output is switched off when storing or transporting the device. This will ensure that the device does not self discharge.



Similar cases can be stacked on this device. Do not over-stack!

Maintenance and Care

It is preferable to charge the device immediately before use.

Some self-discharge would result if the batteries are charged several weeks in advance of their use. However, this slight loss can be re-charged at any time without any degradation of battery performance (no memory effect).

If for some reason, the pack temperature reaches 60°C, then the discharge activity is suspended.

The pack resumes normal charging once the temperature drops back to below 50°C. This is a safety feature incorporated in all BLUESHAPE battery packs.

Disposal Instructions

When the equipment has reached the end of its life please dispose of the components in accordance with your local waste directive in your country.

Electronic equipment should be recycled wherever possible and not disposed of with regular waste.

This page has been intentionally left blank.

This page has been intentionally left blank.

Warranty

BLUESHAPE batteries are warranted to be free from defects in materials, workmanship and functionality for a period of 18 months commencing from the date of purchase. This warranty shall not apply to any products or parts there-of, that have been subjected to misuse, negligence, accidental or abnormal conditions of operation.

The buyer should always contact the place of purchase for any return of defective product. It is important that the buyer provides us with as much information as possible about the failure being claimed.

In the event of product failure for which warranty applies, we will repair or replace the product free of charge. In these cases, all expenses including transport charges will be borne by us.

In the case where the failure has been caused by one of the causes explained above, repairs shall be billed at a nominal cost. Prior to the carrying out of any repairs, we will inform the customer of the estimated costs of these repairs.

These warranty conditions are the only ones applicable to our products and overrule any other expressed or implied warranties. We shall not be held liable for any damages resulting from warranty statements other than those contained in this declaration.

This warranty is not transferable and is only applicable to the original buyer. In all warranty claims, the buyer must reproduce the original purchase invoice.



BLUESHAPE®

is a registered trademark of:

NEW CELL TOP Srl

Via Liguria 4-6,

42124 Reggio Emilia, ITALY

TEL.: +39 0522 518556

WEB: www.blueshape.net

EMAIL: info@blueshape.net