



UN CERTIFIED BATTERY FLIGHT CASE
FOR V-LOCK LITHIUM ION BATTERIES

Model

BX4

OPERATING INSTRUCTIONS

Revision 1.0

Please read these instructions to familiarise yourself with the usage of this flight case

BLUESHAPE in co-operation with a leading professional case manufacturer has created a dedicated solution for helping users ship their video camera batteries based on the guidelines of the UN transport regulations for carrying lithium ion batteries.

This case has been certified by an internationally accredited laboratory and can be used to ship up to 4 units of our larger sized models with airlines and couriers accepting batteries under PI965 1A:

- BV225
- BV190HD
- BV270HD
- BV190HD SPLASH
- BV270HD SPLASH

A sample of this case has undergone various tests, conducted by the commissioned certifying body and their certification imposes terms and conditions in the usage of such cases for carrying Li-Ion batteries in this manner that need to be applied and respected.

Please note:

PI965 1A	Packing instructions apply when shipping Li-Ion batteries greater than 100Wh
----------	--

Mixed models can be included together in the same case. In such event, the battery pack with the highest capacity determines the packing instructions to apply.

Getting familiar with your case

1. Package contents

- UN certified BX4 lithium ion battery transport case with 4 preformed internal battery compartments
- Set of CAO stickers - Cargo Aircraft Only (quantity 5)
- Set of Class 9 stickers (quantity 5)
- Set of SHIPPER / CONSIGNEE stickers (quantity 5)
- Operating manual

2. Product description

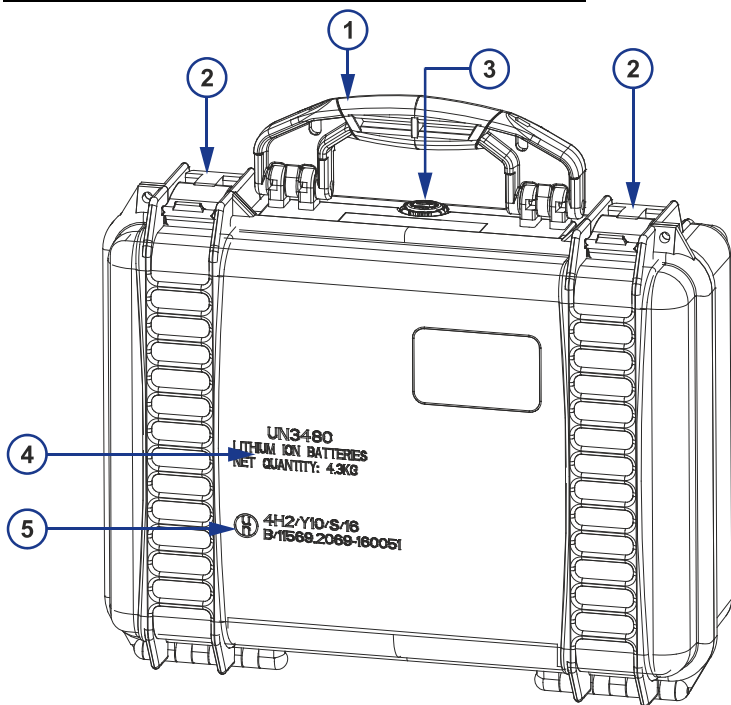

1. Swivelling handle
2. Watertight 2-step latch
3. Purge valve
4. UN number and UN designation
5. UN certification number

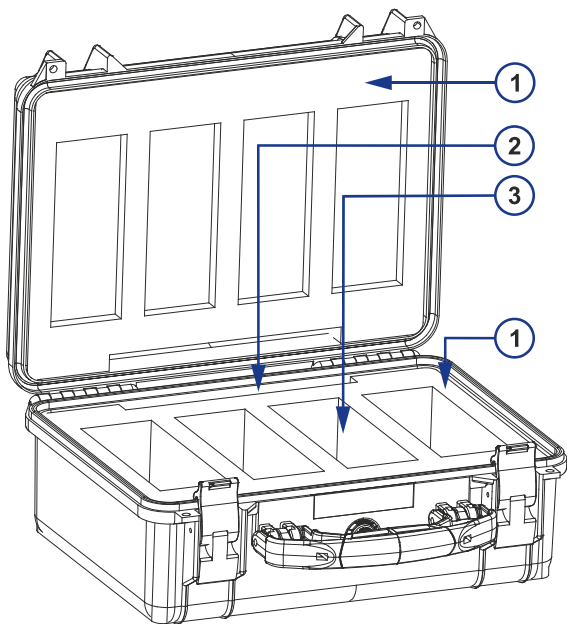

1. Preformed special cushioning foam
2. Document pocket
3. Battery compartments

3. Case properties

The cases we use are made from a special compound based on, but even stronger than polypropylene – the resin normally used for these types of cases. Apart from enhanced robustness, the case is even lighter than normal. The case walls are thinner and more elastic and this makes them more shockproof and impact resistant. All cases are chemical resistant (including acids), scratchproof and capable of resisting extreme weather and temperature conditions. These cases are tested in temperatures ranging from -40°C to 80°C. They are also IP 67 rated.

The internal foam used internally is made of special fire-retardant material and shaped to accommodate 4 BLUESHAPE batteries. The batteries fit tightly and securely inside but at the same time, the cushioning is sufficiently soft to enable quick insertion and removal without risks of scratching the batteries. A document insert has also been provided for user convenience.

4. Purge valve

The purge valve fitted in these cases is an auto press release valve located underneath the case handle that adjusts to changing temperatures automatically. Made from Hydrophobic Acrylic ePTPE, it permits air exchanges at a rate, at least 6 times faster than competition whilst retaining the IP67 rating.



Moreover, by design, the valve cannot unscrew itself and get lost.

5. Latch and pressure release valve procedures

Your BX4 case is equipped with a watertight 2-step latch and O ring system to protect the batteries in the most extreme weather conditions. Changes in atmospheric pressure during travel will create a vacuum tight seal between the lid and the body of the case. The purge valve automatically adjusts or releases pressure according to the environmental conditions. The case has 2 latches.

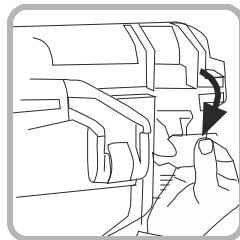
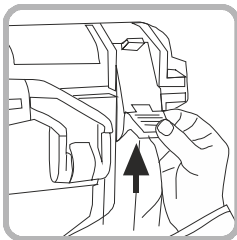

To release and open the latches, proceed as follows:

- lift up from the bottom of the latches
- Pull towards you
- Then pull down and out from opposite end of each latch

6. Case labels and markings

The proper marking is the key for a successful shipment. All stickers and markings are mandatory and specified by international regulations. They must be displayed on the same side of the case without overlapping. Please follow this layout when preparing a case for shipment.

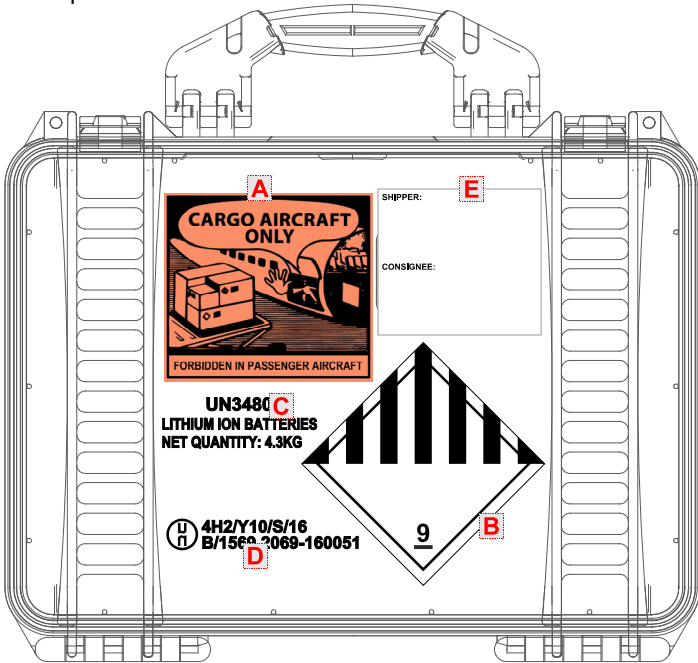

- 6
- A) CAO pictogram (Cargo Aircraft Only)
According to the current IATA regulation, packing instructions PI965 1A is restricted to cargo only flights. For this reason it is mandatory to mark the case with a CAO label. For convenience, 5 spare labels are provided.
- B) Class 9 pictogram
This label indicates the class of miscellaneous dangerous goods that includes UN3480 Lithium Ion batteries. For convenience, 5 spare labels are provided
- C) UN Number, UN Designation, and net weight. It is printed on the case and must not be erased or altered.

- D) UN number certification number, unique to BLUESHAPE cases. It is printed on the case and must not be erased or altered.
- E) Area for SHIPPER / CONSIGNEE label. This label must be applied by the user for every shipment and duly filled-in. For convenience, 5 extra spare labels, pre-printed with the SHIPPER / CONSIGNEE caption are provided.

7. How to use your case for air transport

The case has been designed by BLUESHAPE in order to help users ship batteries in aircraft with a higher degree of safety and convenience. The restrictions for shipping Li-Ion batteries in passenger aircraft or carrying batteries greater than 160Wh on board as carry-on luggage still apply and using the BX4 case does not imply that these rules change in any way.

Batteries greater than 100Wh can be shipped in cargo aircraft only and batteries greater than 160Wh cannot be carried on board.



BLUESHAPE strongly advise that whenever you purchase new batteries, you retain the contacts cover.

The contacts covers should always be installed on each of the 4 batteries being carried inside the case.

The case has been certified for a maximum gross weight of 10 Kg. This gross weight shall not be exceeded. A BX4 case with 4 x BV270HD batteries and documentation inside will weigh around 9.3Kg.

A) Shipping batteries

When shipping UN3480 Li-Ion batteries, the usage of a certified case is mandatory. The BX4 case automatically qualifies as an adequate packaging for batteries as dangerous goods on cargo aircraft. No additional packaging is necessary.

The case must be labelled as indicated, following the proper packing instructions PI965 1A

B) Carrying batteries on board

The case cannot be used to carry on board the batteries for which it is certified, because all these models exceed the 160Wh limit.

8. Specifications

Product	BX4
Description	IATA certified carrying case for BLUESHAPE Li-Ion (UN 3480) batteries with up to 4.3 Kg lithium net weight content
Battery compartments	4
Presentation	Compartments are designed for BLUESHAPE 'Granite' series batteries $\geq 180\text{Wh}$
Dimensions (external)	(406 x 318 x 170) mm
Dimensions (internal)	(379 x 263 x 139) mm
Compartment sizes	(170 x 95 x 52) mm [5 of]
Weight of case (empty)	2.19Kg
Max. weight (full)	10 Kg
Foam material	PE-X-40Kg/m3
Tests	UN regulations – part 6, IMDG – part 6, ICAO –part 6, ADR , RID - part 6
Certificate number	4H2/Y10/S/xx B/1569.2069-160051 <i>(note: xx above represents the last 2 digits of the year of manufacture- for example 16 = 2016)</i>
Notes	The bag may contain an assortment of different BLUESHAPE batteries with different weights and volumes as long as the certified gross weight is not exceeded.

BATTERY MODEL	NET KG CONTENT OF UN3480 CELLS
BV270HD	1.080 x 4 = 4.32 Kg
BV270HD SPLASH	1.080 x 4 = 4.32 Kg
BV190HD	1.080 x 4 = 4.32 Kg
BV190HD SPLASH	1.080 x 4 = 4.32 Kg

Disclaimer

This case can be used to ship up to 4 lithium ion batteries with airlines and couriers accepting UN3480 batteries falling under PI965 1A.

BLUESHAPE wish to make it explicitly clear that usage of this case does not empower users to ignore the regulations and restrictions laid out by IATA for the air transport of Lithium ion batteries.

Users are also reminded that the certification covers only the designated BLUESHAPE batteries. We cannot assume any responsibility if other 3rd party batteries are used.

Users are reminded that different countries and airlines may chose to have their own additional restrictions and regulations.

This page has been intentionally left blank

This page has been intentionally left blank

Warranty

BLUESHAPE products are warranted to be free from defects in materials, workmanship and functionality for a period of 18 months commencing from the date of purchase.

This warranty shall not apply to any products or parts of, that have been subjected to misuse, negligence, accidental or abnormal conditions of operation.

The buyer should always contact the place of purchase for any return of defective product. It is important that the buyer provides us with as much information as possible about the failure being claimed.

In the event of product failure for which warranty applies, we will repair or replace the product free of charge. In these cases, all expenses including transport charges will be borne by us.

In the case where the failure has been caused by one of the causes explained above, repairs should be billed at a nominal cost. Prior to the carrying out of any repairs, we will inform the customer of the estimated costs of these repairs.

These warranty conditions are the only ones applicable to our products and overrule any other expressed or implied warranties. We shall not be held liable for any damages resulting from warranty statements other than those contained in this declaration.

In all warranty claims, the buyer must reproduce the original purchase invoice.



NEW CELL TOP Srl
VIA LIGURIA 4-6,
42124 REGGIO EMILIA, ITALY
TEL. +39 0522 518556
FAX. +39 0522 277084
WEB: www.blueshape.net
EMAIL: info@blueshape.net